

APPLICATION NOTE

AN166

Basic feedback theory

1988 Dec

Basic feedback theory

AN166

BASIC FEEDBACK THEORY

In AN165, the ideal op amp was defined. The ideal parameters are never fully realized but they present a very convenient method for the preliminary analysis of circuitry. So important are these ideal definitions that they are repeated here. The ideal amplifier possesses

1. Infinite gain
2. Infinite input impedance
3. Infinite bandwidth
4. Zero output impedance

From these definitions two important theorems are developed.

1. No current flows into or out of the input terminals.
2. When negative feedback is applied, the differential input voltage is reduced to zero.

Keeping these rules in mind, the basic concept of feedback can be explored.

VOLTAGE-FOLLOWER

Perhaps the most often used and simplest circuit is that of a voltage-follower. The circuit of Figure 1 illustrates the simplicity.

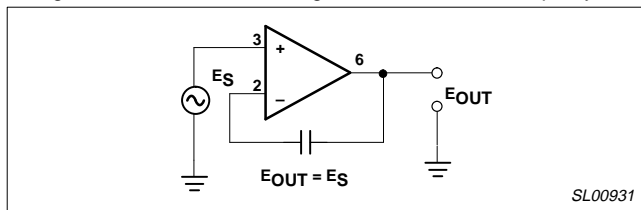

Figure 1. Voltage-Follower

Applying the zero differential input theorem, the voltages of Pins 2 and 3 are equal, and since Pins 2 and 6 are tied together, their voltage is equal; hence, $E_{OUT} = E_{IN}$. Trivial to analyze, the circuit nevertheless does illustrate the power of the zero differential voltage theorem. Because the input impedance is multiplied and the output impedance divided by the loop gain, the voltage-follower is extremely useful for buffering voltage sources and for impedance transformation.

The basic configuration in Figure 1 has a gain of 1 with extremely high input impedance. Setting the feedback resistor equal to the source impedance will cancel the effects of bias current if desired.

However, for most applications, a direct connection from output to input will suffice. Errors arise from offset voltage, common-mode rejection ratio, and gain. The circuit can be used with any op amp with the required unity gain compensation, if it is required.

NON-INVERTING AMPLIFIER

Only slightly more complicated is the non-inverting amplifier of Figure 2.

The voltage appearing at the inverting input is defined by

$$E_2 = \frac{E_{OUT} \cdot R_{IN}}{R_F + R_{IN}} \quad (1a)$$

Since the differential voltage is zero, $E_2 = E_S$, and the output voltage becomes

$$E_{OUT} = E_S \left(1 + \frac{R_F}{R_{IN}} \right) \quad (1b)$$

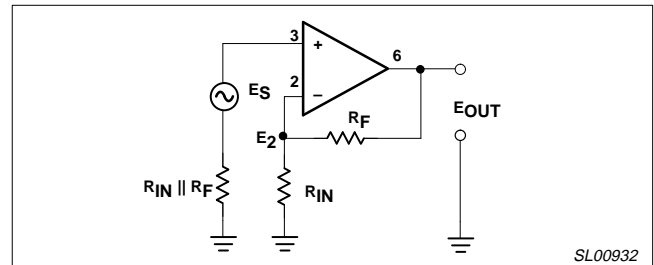

Figure 2. Non-Inverting Amplifier

It should be noted that as long as the gain of the closed-loop is small compared to open-loop gain, the output will be accurate, but as the closed-loop gain approaches the open-loop value more error will be introduced.

The signal source is shown in Figure 2 in series with a resistor equal in size to the parallel combination of R_{IN} and R_F . This is desirable because the voltage drops due to bias currents to the inputs are equal and cancel out even over temperature. Thus overall performance is much improved.

The amplifier does not phase-invert and possesses high input impedance. Again the impedances of the two inputs should be equal to reduce offsets due to bias currents.

INVERTING AMPLIFIER

By slightly rearranging the circuit of Figure 2, the non-inverting amplifier is changed to an inverting amplifier. The circuit gain is found by applying both theorems; hence, the voltage at the inverting input is 0 and no current flows into the input. Thus the following relationships hold:

$$\frac{E_S}{R_{IN}} + \frac{E_O}{R_F} = 0 \quad (2a)$$

Solving for the output E_O

$$E_O = E_S \frac{R_F}{R_{IN}} \quad (2b)$$

As opposed to the non-inverting circuits the input impedance of the inverting amplifier is not infinite but becomes essentially equal to R_{IN} . This circuit has found widespread acceptance because of the ease with which input impedance and gain can be controlled to advantage, as in the case of the summing amplifier.

With the inverting amplifier of Figure 3, the gain can be set to any desired value defined by R divided by R_{IN} . Input impedance is defined by the value of R_{IN} and R should equal the parallel combination of R_{IN} and R to cancel the effect of bias current. Offset voltage, offset current, and gain

Basic feedback theory

AN166

contribute most of the errors. The ground may be set anywhere within the common-mode range and any op amp will provide satisfactory response.

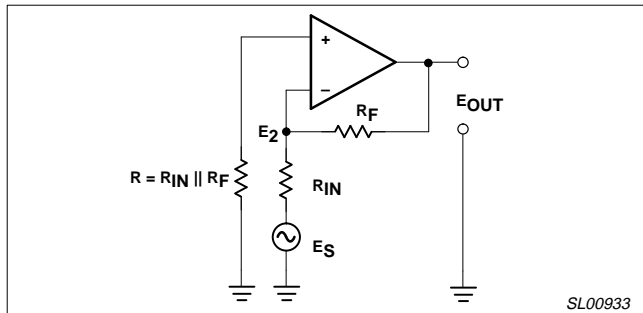

Figure 3. Inverting Amplifier

CURRENT-TO-VOLTAGE CONVERTER

The transfer function of the current-to-voltage converter is

$$V_{OUT} = I_{IN} R_1 \tag{3}$$

Evaluation of the circuit depends upon the virtual ground theorem developed earlier. The current flowing into the input must be the same as that flowing across R1, hence, the output voltage is the IR drop of R1.

Limitations, of course, are output saturation voltage and output current capability. The inputs may be biased anywhere within the common-mode range.

DIFFERENTIAL AMPLIFIER

This circuit of Figure 5 has a gain with respect to differential signals of R2/R1.

The common-mode rejection is dominated by the accuracy of the resistors. Other errors arise from the offset voltage, input offset current, gain and common-mode rejection. The circuit can be used with any op amp discussed in this chapter with the proper compensation.

SUMMING AMPLIFIER

The summing amplifier is a variation of the inverting amplifier. The output is the sum of the input voltages, each being weighed by R_F/R_IN.

The value of R4 may be chosen to cancel the effects of bias current and is selected equal to the parallel combination of R_F and all the input resistors.

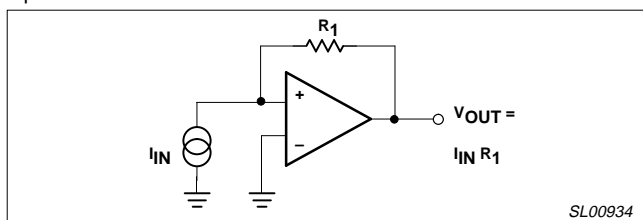

Figure 4. Current-to-Voltage Converter

INTEGRATOR

Integration can be performed with a variation of the inverting amplifier by replacing the feedback resistor with a capacitance. The transfer function is defined by

$$V_{OUT} = \frac{1}{RC} \int_0^t V_{IN} \cdot dt \tag{4}$$

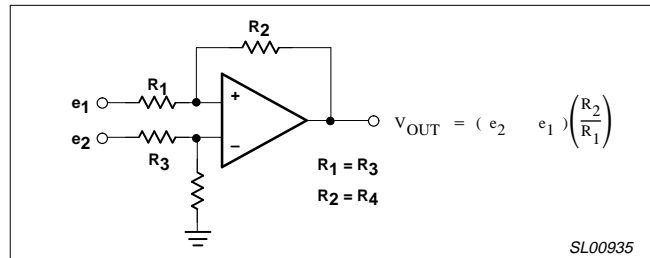

Figure 5. Differential Amplifier

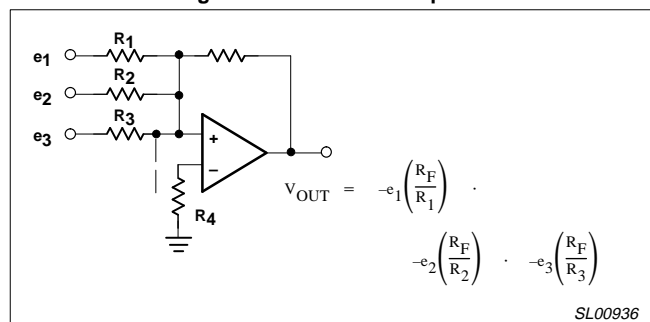

Figure 6. Summing Amplifier

The gain of the circuit falls at 6dB per octave over the range in which strays and leakages are small.

Since the gain at DC is very high a method for resetting initial conditions is necessary. Switch S1 removes the charge on the capacitor. A relay or FET may be used in the practical circuit. Bias and offset currents and offset voltage of the switch should be low in such an application.

DIFFERENTIATOR

The differentiator of Figure 8 is another variation of the inverting amplifier. The gain increases at 6dB per octave until it intersects the amplifier open-loop gain, then decreases because of the amplifier bandwidth. This characteristic can lead to instability and high frequency noise sensitivity.

A more practical circuit is shown in Figure 9. The gain has been reduced by R3 and the high frequency gain reduced by C2, allowing better phase control and less high frequency noise. Compensation should be for unity gain.

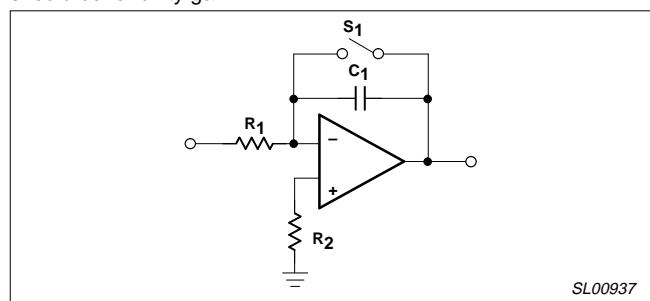

Figure 7. Integrator

Basic feedback theory

AN166

COMPENSATION

Present-day operational amplifiers are comprised of multiple stages, each of which has a 3dB point or pole associated with it. Referring to Figure 10, the 3dB breakpoints of a two-stage amplifier are approximated by the Bode plot.

As with any feedback loop, the op amp must be protected from phase shifts in excess of 360°. A steady 180° phase shift is developed by the amplifier from output to inverting input. In addition, the sum of all additional shifts due to amplifier poles or feedback component poles will cause the necessary additional 180° to sustain oscillation if the gain of the amplifier is greater than one for the frequency at which the 180° phase shift is reached. By adding poles and zeros to the amplifier response externally, the phase shift can be controlled to insure stability.

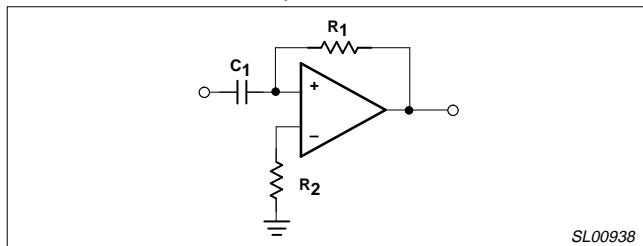

Figure 8. Differentiator

Many op amps now include internal compensation. These are single capacitors of 30pF, typically, and the amplifier will remain stable for all gains. However, since they are unconditionally stable, the compensation is larger than required for most applications. The resultant loss of bandwidth and slew rate may be acceptable in the general case, but selection of an externally-compensated device can add a great deal to the amplifier response if the compensation is handled properly.

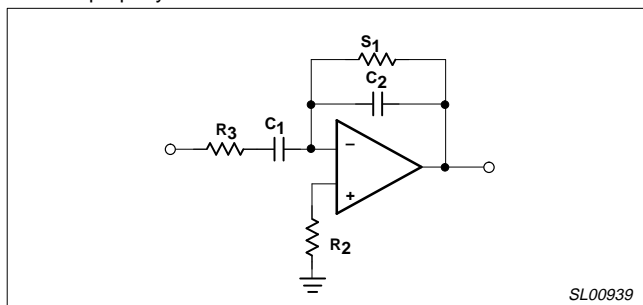

Figure 9. Practical Differentiator

In order to fully develop the point at which instability occurs, a fuller understanding of phase response is necessary.

The diagram of Figure 11 depicts the phase shift of a single pole. Note that at the pole position the phase shift is 45° and that phase shift becomes 0° for a decade below the pole and -90° for a decade above the pole location. This is a Bode approximation which possesses a 5.7° error at 0° and 90°, but this error is usually considered small enough to be ignored. The single pole produces a maximum of 90° phase shift and also produces a frequency roll-off of 20dB per decade.

The addition of the second pole of Figure 12 produces an additional 90° phase shift and increases the roll-off slope to -40dB per decade. At this point, phase shift could exceed 180° because unity gain is reached, causing stability. For gain levels equal to A1 or 1/β, the phase shift is only 90° and the amplifier is stable. However, with a β gain of A2 the phase shift is 180° and the loop is unstable. Gains in

between A1 and A2 are marginally stable. As shown in Figure 13, the phase shift as it approaches 180° causes increasing frequency peaking and overshoot until sustained oscillations occur.

It is generally accepted in the interest of minimized frequency peaking to limit the phase shift of the amplifier to 135° or a phase margin of 45°. At this margin the second-order response of the system is critically damped and oscillation is prevented.

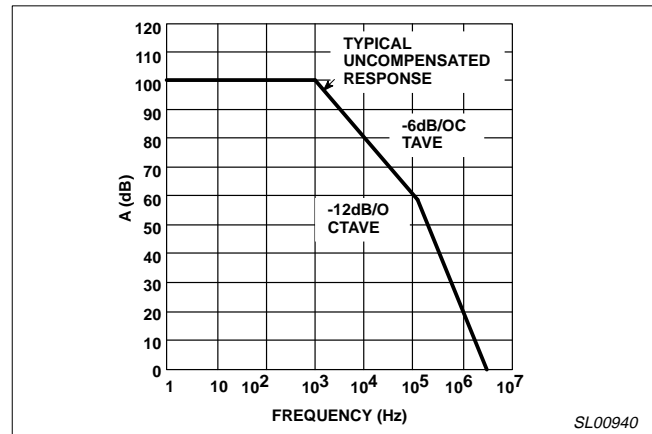

Figure 10. Frequency Compensation

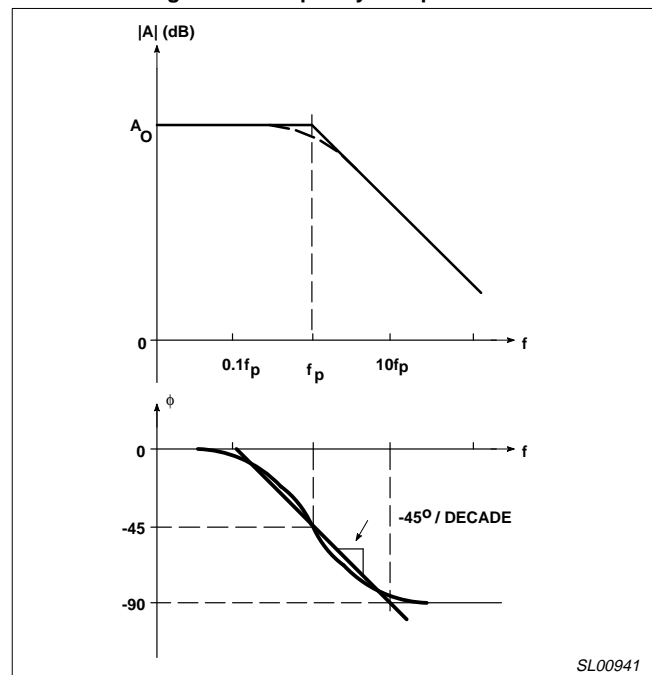

Figure 11. Single-Pole Amplitude and Phase Response

Referring to Figure 14, the required compensation can be determined. Given the open-loop response of the amplifier, the desired gain is plotted until it intercepts the open-loop curve as shown.

The phase shift for minimum peaking is 135°. Remembering that phase shift is 45° at the frequency pole, the example of Figure 14 will be unstable at gains less than 20dB where phase shift exceeds 180°, and will possess excessive overshoot and ringing at gains less than 60dB where phase shift exceeds 135°. Thus, the desired compensation will move the second pole of the amplifier out in frequency until the closed-loop gain intersects the open-loop

Basic feedback theory

AN166

response before the second break of the amplifier occurs. Selecting only enough compensation to do the job assures the maximum bandwidths and slew rates of the amplifier. Additional in-depth information on compensation can be found in the reference material.

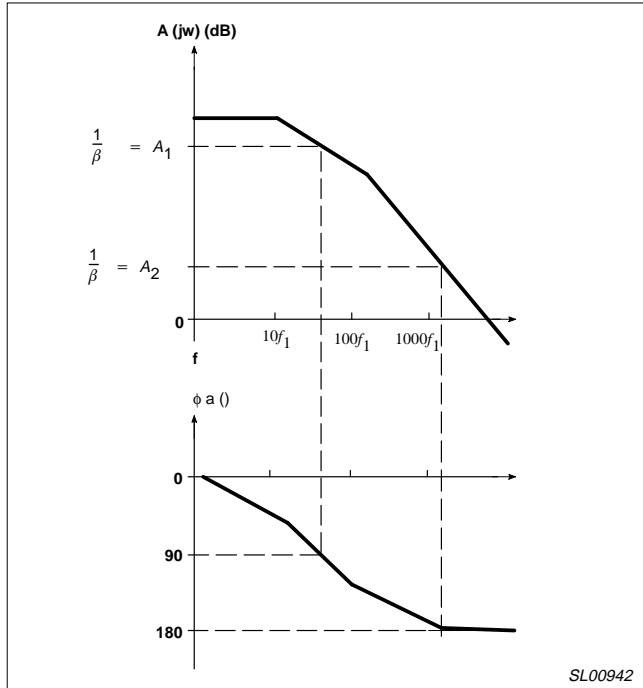

Figure 12. Two-Pole Closed-Loop Response

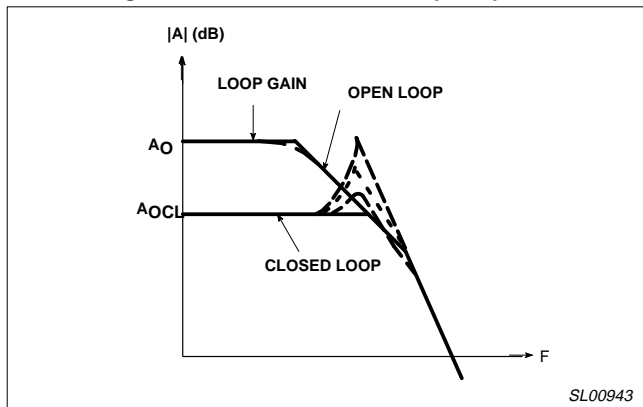

Figure 13. Frequency Peaking Due to Insufficient Phase Margin

FEED-FORWARD COMPENSATION

External compensation has been shown to improve amplifier bandwidth over internal compensation in the preceding section. Additional bandwidth can be realized if feed-forward compensation is used.

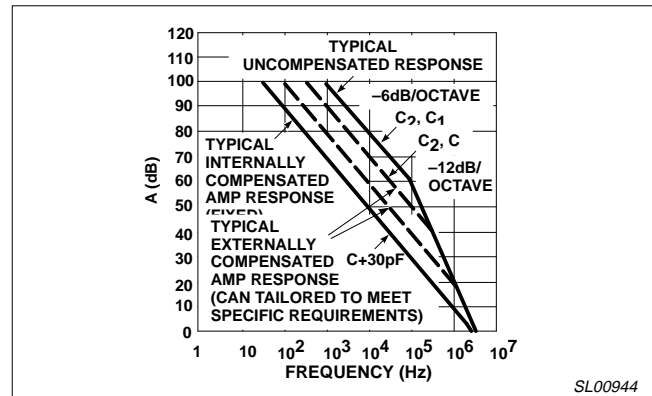

Figure 14. Frequency Compensation

Bandwidth is limited in monolithic design by the poor frequency response of the PNP level shifters of the first stage.

The concept of feed-forward compensation bypasses the input stage at high frequencies driving the higher frequency second stage directly as pictured by Figure 15. The Bode plot of Figure 16 shows the additional response added by the feed-forward technique. The response of the original amplifier requires less compensation at lower frequencies allowing an order of magnitude improvement in bandwidth. Standard compensation and feed-forward are both plotted to illustrate the bandwidth improvement. Unfortunately, the use of feed-forward compensation is restricted to the inverting amplifier mode.

REFERENCES

1. OPERATIONAL AMPLIFIERS-Design & Applications, Jerald Graeme and Gene Tobey, McGraw Hill Book Company.

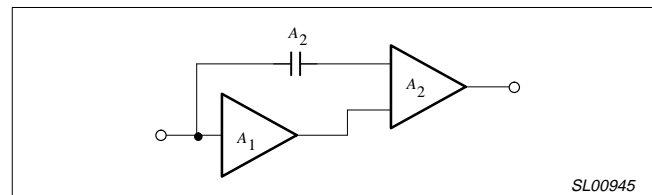

Figure 15. Technique of Feed-Forward Around 1st Stage

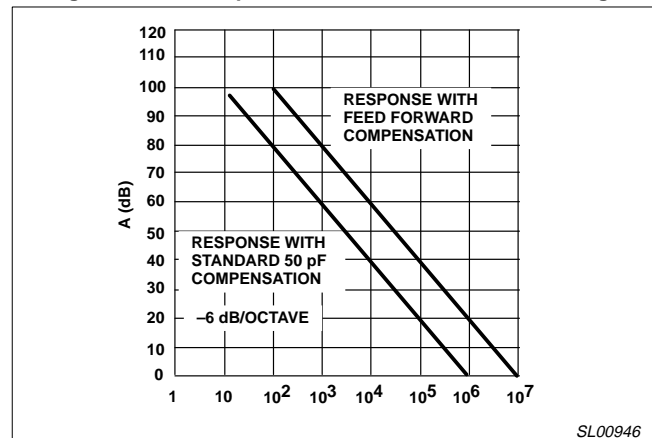

Figure 16. Frequency Response With Feed-Forward Compensation